

NOTE: SE NON DIVERSAMENTE SPECIFICATO

1. IL TAU TUBE DEVE ESSERE INSTALLATO SECONDO ISTRUZIONI DEL COSTRUTTORE.
2. PER I DETTAGLI VEDERE LE PAGINE 3 E 4.
3. IL COMPONENTE POS. 36 NON VIENE MOSTRATO

NOTES UNLESS OTHERWISE SPECIFIED

1. TAU TUBE TO BE INSTALLED PER MANUFACTURER'S INSTRUCTIONS..
2. SEE PAGE 3 AND 4 FOR DETAILS..
3. THE COMPONENT POS. 36 IT IS NOT SHOWN

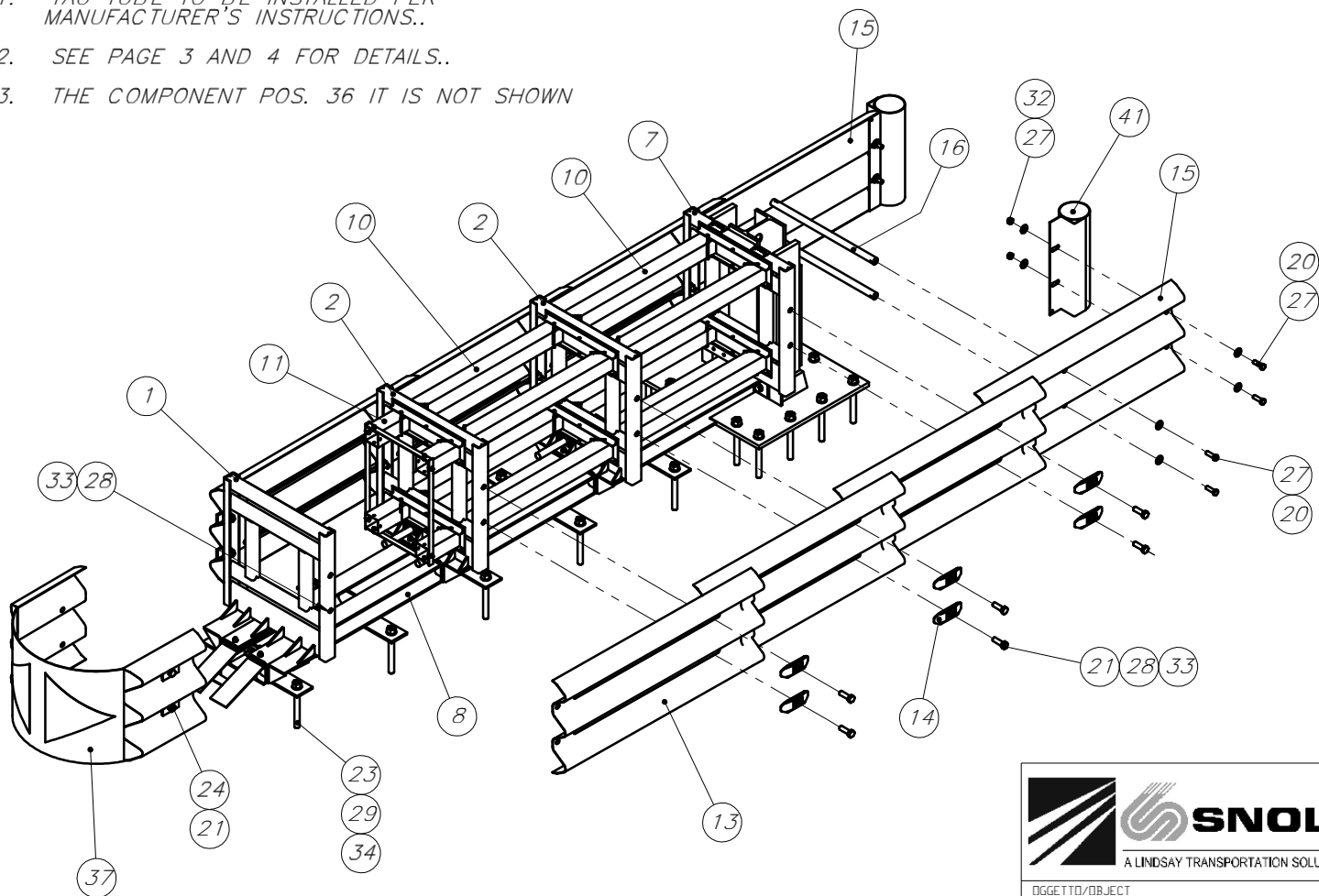

POS.	DESCRIZIONE	DESCRIPTION	TH. Kg	CODE	QTY.
1	Supporto anteriore	Front support	43	TUB0024	1
2	Supporto intermedio	Intermediate support	41,3	TUB0021	2
3	Rotella per carrello	Small wheel	1,18	TUB0025	12
4	Pannello anteriore	Front panel	0,71	TUB0038	2
5	Pannello	Panel	0,35	TUB0027	4
6	Ammortizzatore	Shock absorber	0,3	TUB0042	4
7	Gruppo posteriore	Backstop	233,4	TUB0008	1
8	Guida	Front rail	153,5	TUB0049	1
9	Terminale per guida	Terminal for rail	3,3	TUB0047	1
10	Tubo 80x80x2 L=920	Tube 80x80x2 L=920	1,45	TUB0007	8
11	Tubo 80x80x2 L=200	Tube 80x80x2 L=200	0,34	TUB0046	4
12	Supporto tubi	Tubes support	1,1	TUB0045	1
13	Lama L=1250	3-beam panel L=1250	21	TUB0009	6
14	Cursore	Slider	0,8	TAU0179	12
15	Lama terminale	Final 3-beam panel	22,5	TAU0020	2
16	Traversa trasversale	Tube crosspiece	1	TUB0028	2
17	Vite TEM16 a collo	Screw HH M16		TUB0029	12
18	Vite TEM8x20	Screw HH M8x20		480608	8
19	Vite TEM10x70 par z. filet.	Screw HH M10x70 thread part.		480625	8
20	Vite TEM16x50	Screw HH M16x50		480609	8
21	Vite TEM20x60	Screw HH M20x60		480610	20
22	Vite TSEM10x35	Screw FSH M10x35		481058	12
23	Barra filetata M24x250	Threaded Bar M24x250		481510	22
24	Piastrina	Plate	0,3	TUB0041	4
25	Rondella M8	Washer M8		480634	16
26	Rondella M10	Washer M10		510173	20
27	Rondella M16 (øi17xøe40)	Washer M16 (øi17xøe40)		481219	12
28	Rondella M20	Washer M20		480639	24
29	Rondella M24	Washer M24		481509	22
30	Dado M8	Nut M8		480662	8
31	Dado M10	Nut M10		480664	20
32	Dado M16	Nut M16		480665	16
33	Dado M20	Nut M20		480642	20
34	Dado M24	Nut M24		481508	22
35	Fascetta autobloc. (7,9x360)	Clamp (7,9x360)		480618	20
36	Pasta chimica	Chemical Paste		MAL-HIL	3
37	Naso	Nose		TN880Y	1
38	Rivetto Al ø4,8x20 test a larga	AL rivet ø4,8x20-large		510236	4
39	Targhetta identificazione	Identification plate		TAU0114	1
40	Targhetta marchio CE	CE plate		TUB0059	1
41	Tubo per lama terminale	Tube for final 3-beam panel	8	TAU0025	2

 A LINDSAY TRANSPORTATION SOLUTIONS COMPANY					
		A	AGG. TUBO PER LAMA TERM. POS. 41	17.11.14	RBC
DIS./DWG.	DATA/DATE	MATERIALE/MATERIAL	FINITURA/FINISH		
RBC	27.05.14	//	//		
COMMITTENTE	SCALA/SCALE	VISTO/CHKD	DISEGNO N° / Dwg. N°	REV	
SDST. IL DIS N°	//	VDG	085U08CYT4-EXP	A	
IL PRESENTE DISEGNO E LE INFORMAZIONI IN ESSO CONTENUTE SONO IN ESCLUSIVA PROPRIETA' DELLA SNOLINE E' VIETATA SENZA PREVENTIVA AUTORIZZAZIONE SCRITTA, OGNI RIPRODUZIONE Art.99-L.22/4/1941 - N°633					

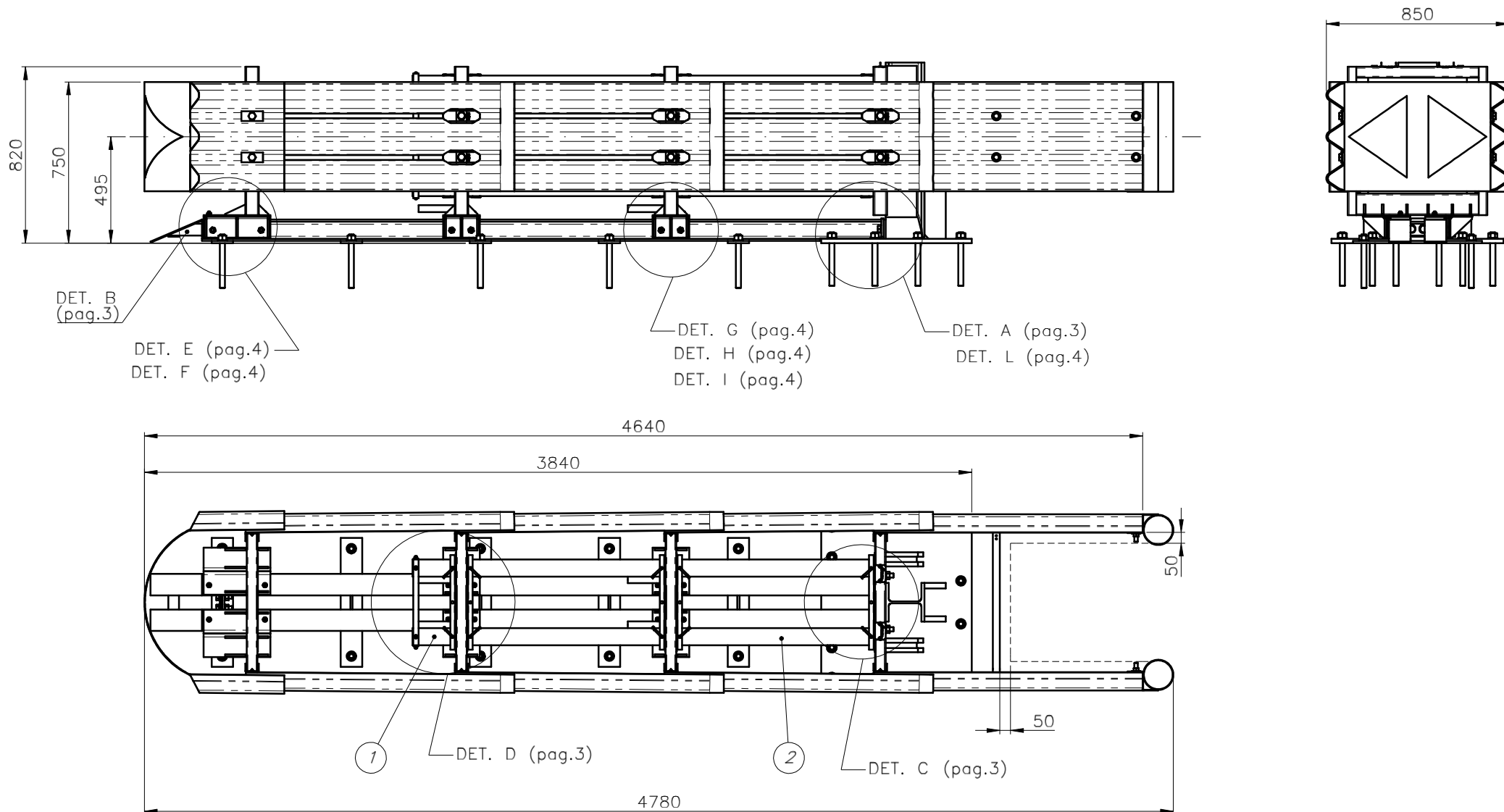

 A LINDSAY TRANSPORTATION SOLUTIONS COMPANY						
		A REV	AGG. TUBO PER LAMA TERM. PDS. 41 DESCRIZIONE	17.11.14 DATA	RBC FIRMA	
OGGETTO/OBJECT ATTENUATORE TAU TUBE P80 TAU TUBE ATTENUATOR P80		DIS./DWG. RBC	DATA/DATE 27.05.14	MATERIALE/MATERIAL //	FINITURA/FINISH //	
COMMITTENTE SDST. IL DIS N°		SCALA/SCALE //	VISTO/CHKD VDG	DISEGNO N° / Dwg. N° 085U08CYT4-DIM	REV A	
IL PRESENTE DISEGNO E LE INFORMAZIONI IN ESSO CONTENUTE SONO IN ESCLUSIVA PROPRIETA' DELLA SNOLINE E' VIETATA SENZA PREVENTIVA AUTORIZZAZIONE SCRITTA, OGNI RIPRODUZIONE Art.99-L.22/4/1941 - N°633						

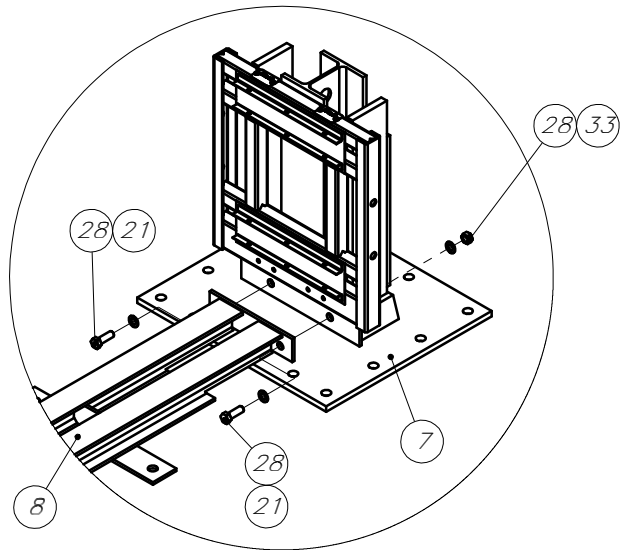

DET. A

BAIA 1° CON N°4 TUBI
DISPOSTI COME DET. D
BAY 1° HAVE N°4 TUB
ARE POSITIONED AS DET. D

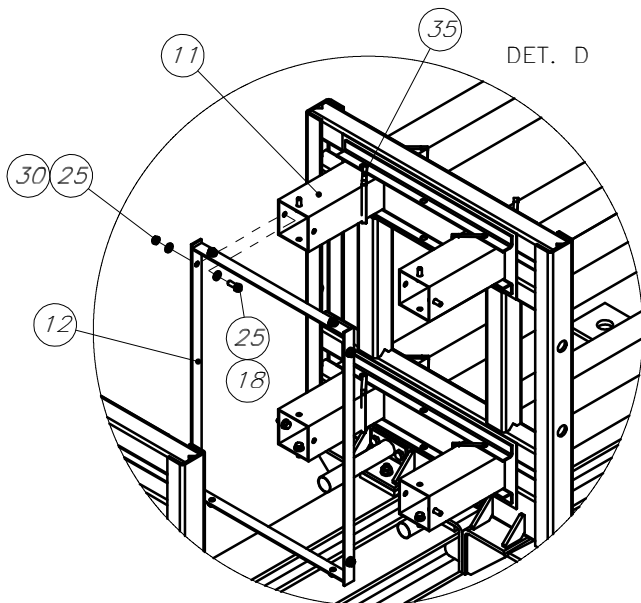

DET. D

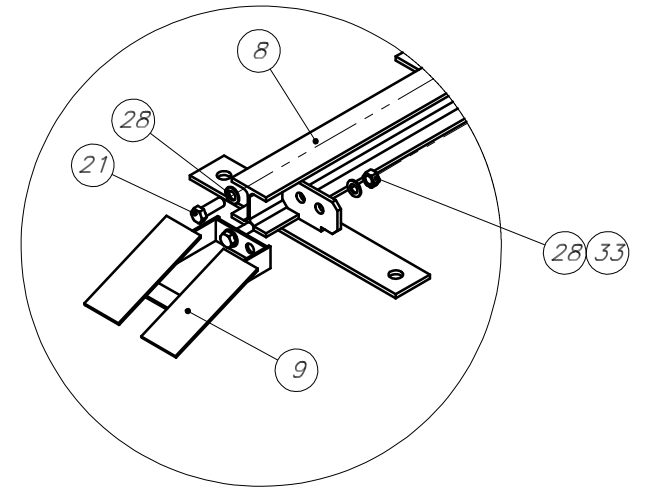

DET. B

BAIA 2°, 3° CON N°4 TUBI
DISPOSTI COME DET. C
BAY 2°, 3° HAVE N°4 TUBE
ARE POSITIONED AS DET. C

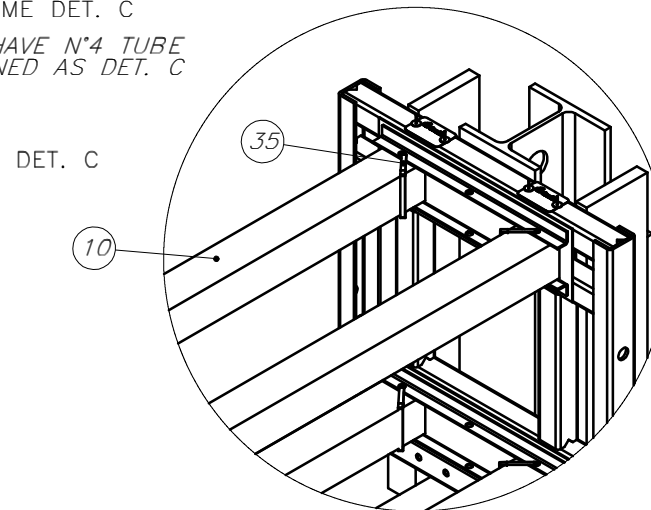

DET. C

 A LINDSAY TRANSPORTATION SOLUTIONS COMPANY					
		A AGG. TUBO PER LAMA TERM. POS. 41 REV	17.11.14 DATA	RBC FIRMA	
OGGETTO/OBJECT ATTENUATORE TAU TUBE P80 TAU TUBE ATTENUATOR P80		DIS./DWG. RBC	DATA/DATE 27.05.14	MATERIALE/MATERIAL //	FINITURA/FINISH //
COMMITTENTE SDST. IL DIS N°		SCALA/SCALE //	VISTO/CHKD VDG	DISEGNO N° / Dwg. N° 085U08CYT4-DET1	REV A
IL PRESENTE DISEGNO E LE INFORMAZIONI IN ESSO CONTENUTE SONO IN ESCLUSIVA PROPRIETA' DELLA SNOLINE E' VIETATA SENZA PREVENTIVA AUTORIZZAZIONE SCRITTA, OGNI RIPRODUZIONE Art.99-L.22/4/1941 - N°633					

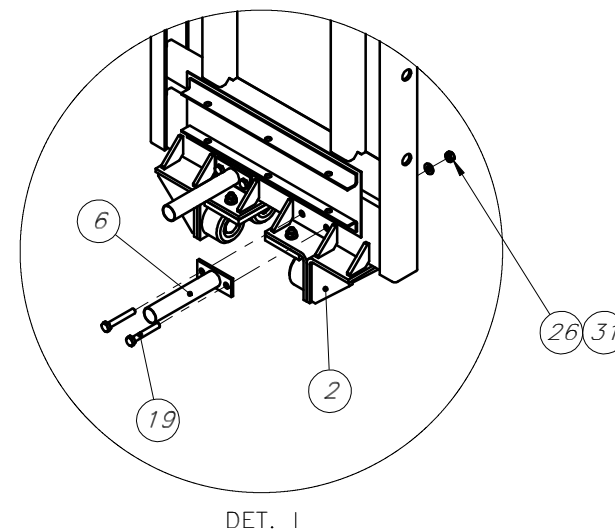
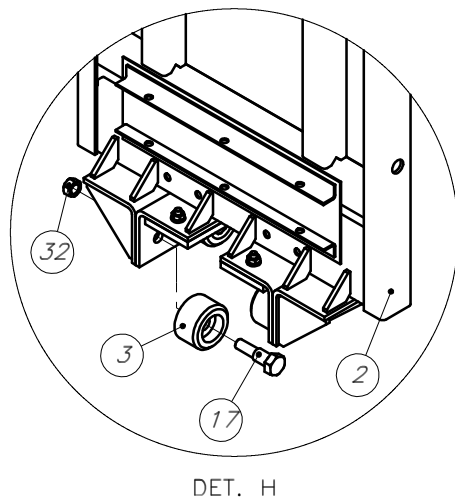
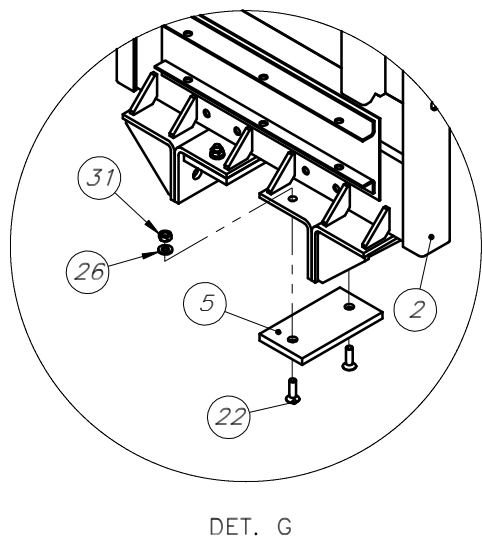
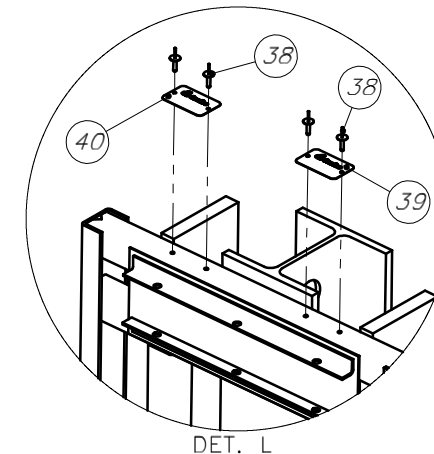
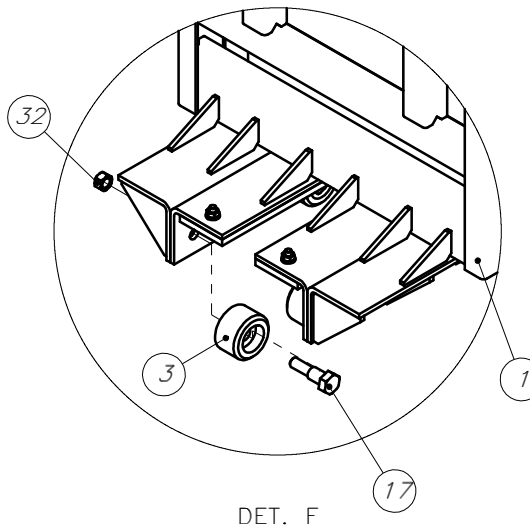
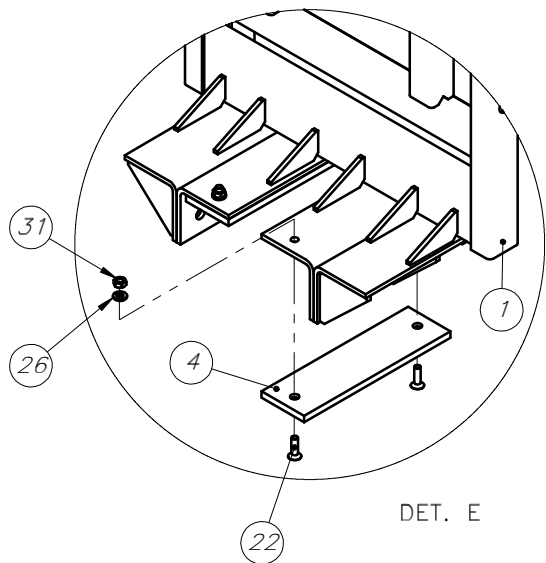

 A LINDSAY TRANSPORTATION SOLUTIONS COMPANY					
		A AGG. TUBO PER LAMA TERM. PDS. 41 REV	DESCRIZIONE DATA	DATA 17.11.14	FIRMA RBC
OGGETTO/OBJECT ATTENUATORE TAU TUBE P80 TAU TUBE ATTENUATOR P80		DIS./DWG. RBC	DATA/DATE 27.05.14	MATERIALE/MATERIAL //	FINITURA/FINISH //
COMMITTENTE SDST. IL DIS N°		SCALA/SCALE //	VISTO/CHKD VDG	DISEGNO N° / Dwg. N° 085U08CYT4-DET2	REV A
IL PRESENTE DISEGNO E LE INFORMAZIONI IN ESSO CONTENUTE SONO IN ESCLUSIVA PROPRIETA' DELLA SNOLINE E' VIETATA SENZA PREVENTIVA AUTORIZZAZIONE SCRITTA, OGNI RIPRODUZIONE Art.99-L.22/4/1941 - N°633					