

DETTAGLIO D
SCALA 1:5

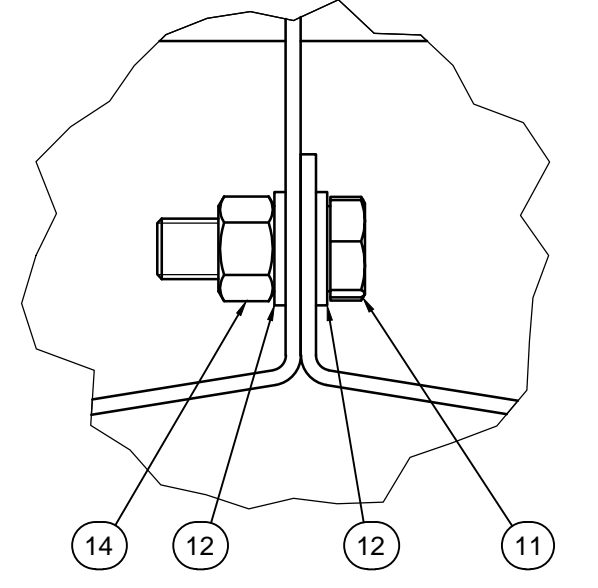

A-A
SCALA 1:5

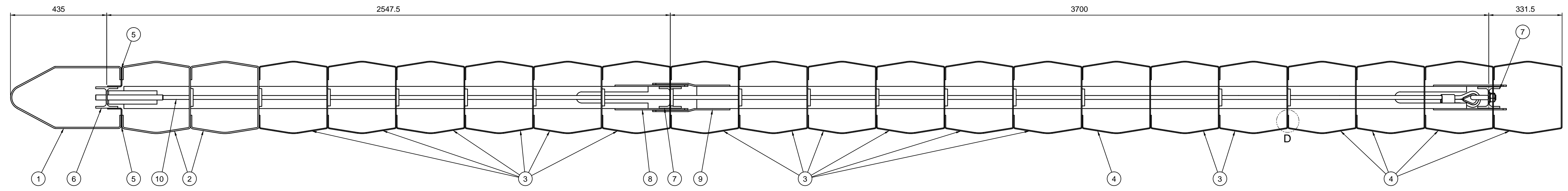
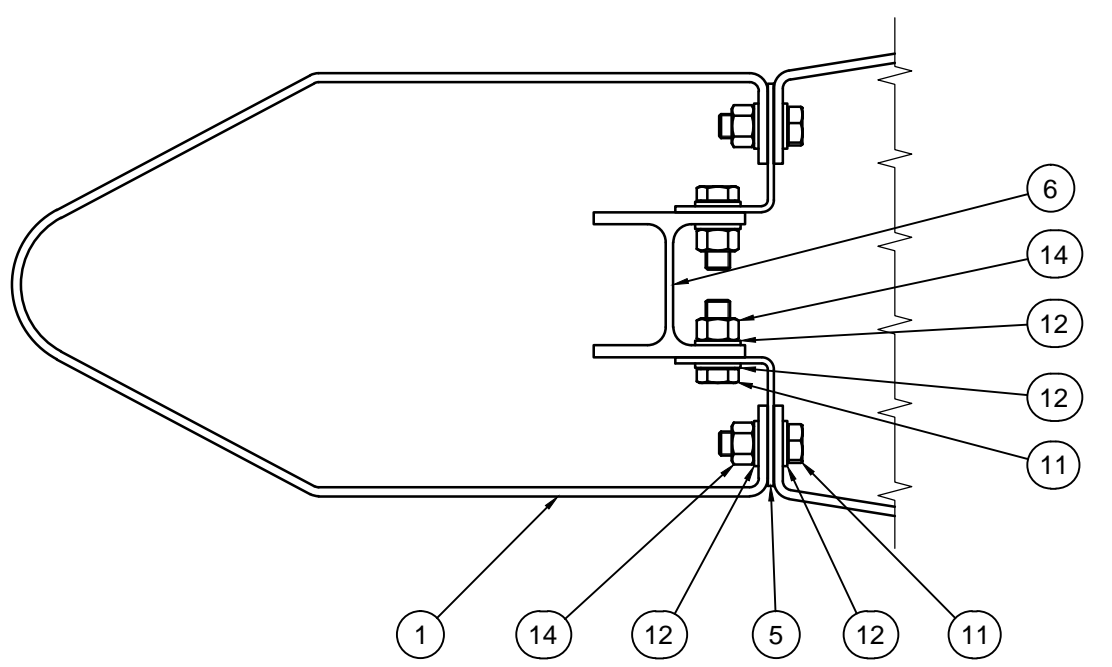

B-B
SCALA 1:5

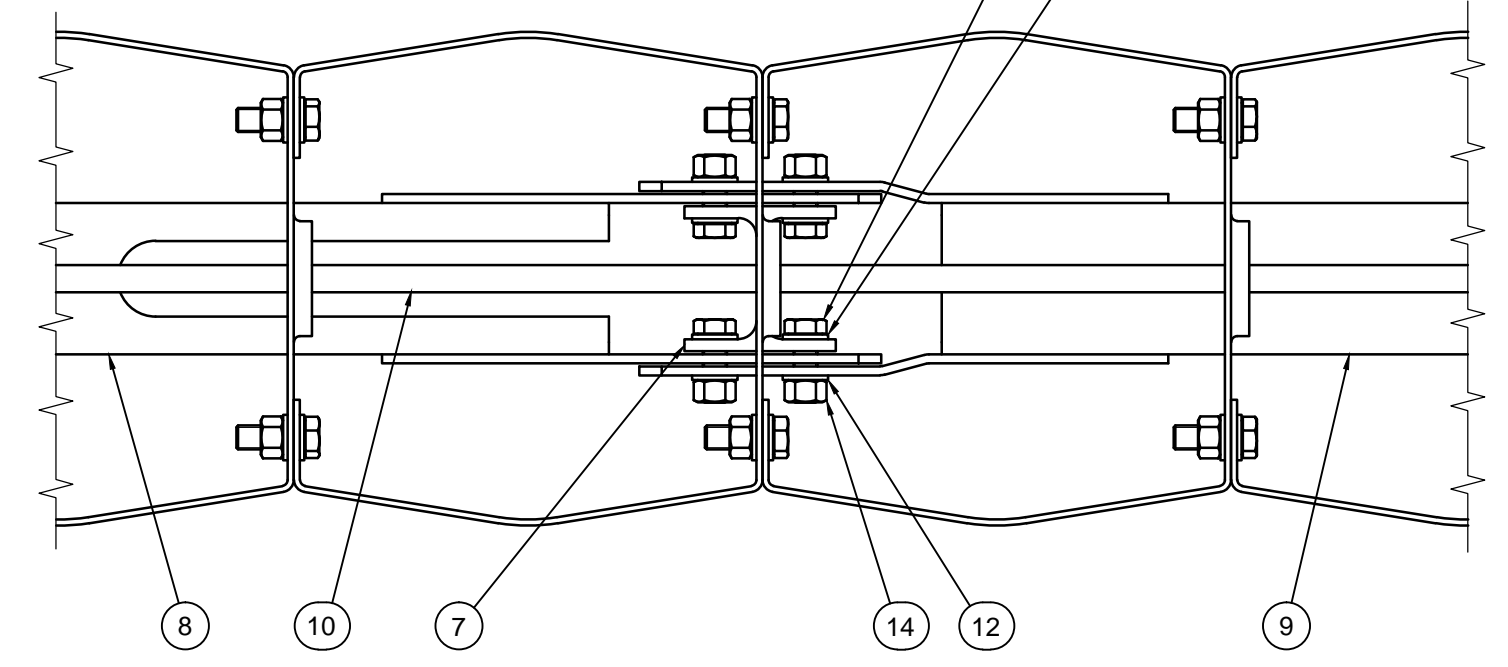

C-C
SCALA 1:5

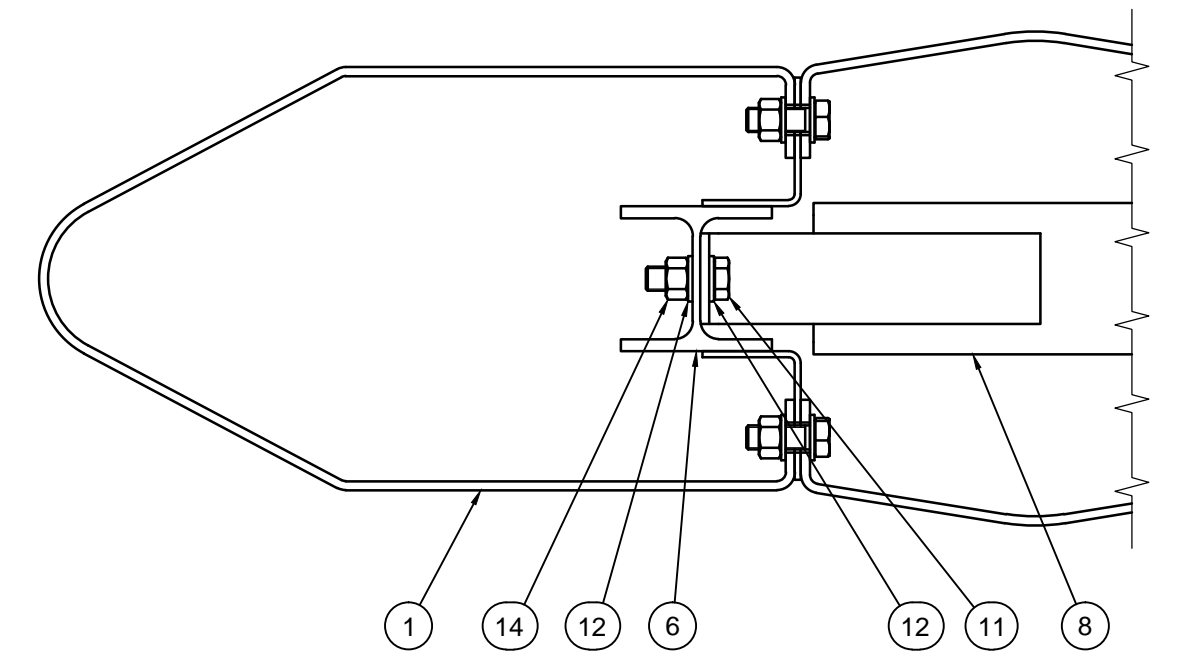
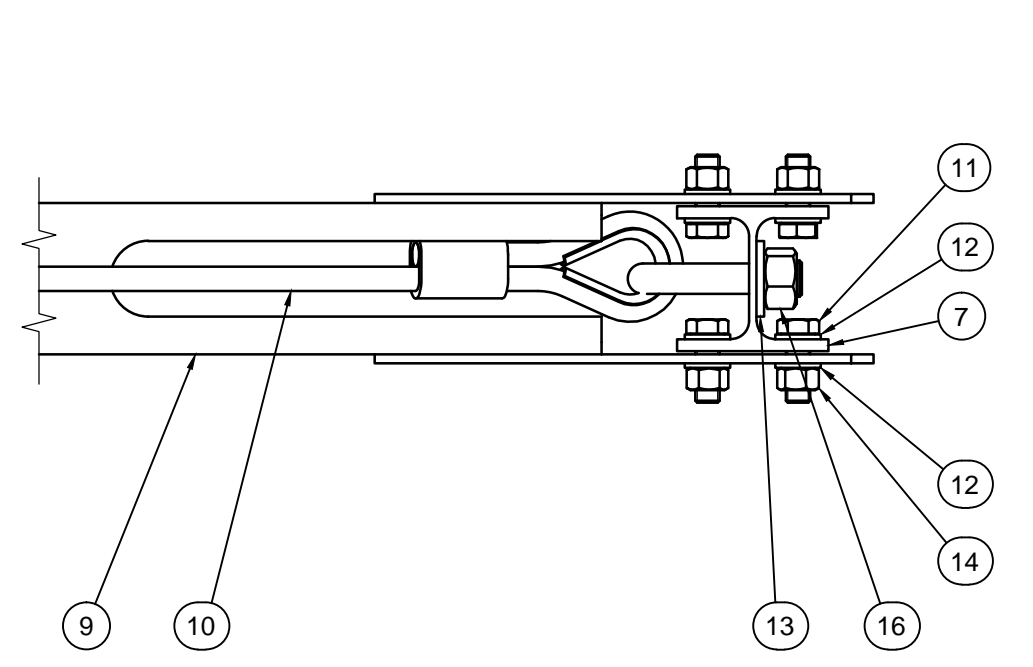

CONFIGURATION FOR TWO WAVES BEAM

POS.	DISEGNO N°	DESCRIZIONE	MATERIALE	QTA	PESO [kg]
16		DADO M24 ISO4032		8	0.13
15		RONDELLA PIANA PER M24 ISO7089	100HV	3	0.03
14		DADO M16 ISO4032		8	169
13	95	PIASTRINA 90x50x5 FORATA Ø24	S235JR	2	0.16
12		RONDELLA PIANA PER M16 ISO7089	100HV	338	0.01
11		VITE M16x45 ISO4017		8.8	169
10	87	FUNE METALLICA D=18 mm CON MANICOTTO FILETTATO M24, REDANCIA E GOLFARE M24		1	13.51
9	86	PROFILO U DI SCORRIMENTO L=3480 mm	S235JR	1	29.95
8	55	PROFILO U DI SCORRIMENTO L=2370 mm	S235JR	1	20.33
7	85	PROFILO HE100A L=650 mm	S275JR	2	10.70
6	46	PROFILO HE100A L=1400 mm	S275JR	1	23.19
5	44	PROFILO ANGOLARE H=750 mm	S235JR	2	3.31
4	52	ELEMENTO D H=480 mm	S235JR	5	15.04
3	51	ELEMENTO C H=750 mm	S235JR	14	23.47
2	82	ELEMENTO E H=750 mm SP. 6 mm	S355JR	2	34.81
1	84	ELEMENTO F H=750 mm SP. 6 mm	S355JR	1	41.16
POS.	DISEGNO N°	DESCRIZIONE	MATERIALE	QTA	PESO [kg]

REV. N°	DESCRIZIONE REVISIONE			SCALA	FORMATO	SOSTITUISCE
	DISEGNATO	CONTROLLATO	APPROVATO			
DATA	07/12/2014	07/12/2014	07/12/2014	1:10	1050x420	
FIRMA	P.P.	S.D.	S.D.			

Unit 232
 Blanchardstown Corporate Park 2
 Dublin 15
 Republic of Ireland
 Tel: 00353 1 9565151

OGGETTO: P4 TERMINAL, TESTED ACCORDING TO ENV 1317-4

PESO

DISEGNO N° 83